

**CURRENT MODE SWITCHING  
POWER SUPPLY CONTROL CIRCUIT**

- DIRECT DRIVE OF THE EXTERNAL SWITCHING TRANSISTOR
- POSITIVE AND NEGATIVE OUTPUT CURRENTS UP TO 0.5 A
- CURRENT LIMITATION
- TRANSFORMER DEMAGNETIZATION SENSING
- FULL OVERLOAD AND SHORT-CIRCUIT PROTECTION
- PROPORTIONAL BASE CURRENT DRIVING
- LOW STANDBY CURRENT BEFORE STARTING (< 1.6 mA)
- THERMAL PROTECTION

**DESCRIPTION**

The TEA2018A is an 8-pin DIP low-cost integrated circuit designed for the control of switch mode power supplies.

Due to its current mode regulation, the TEA2018A facilitates design of power supplies with following features :

- High stability regulation loop
- Automatic input voltage feed-forward in discontinuous mode fly-back
- Automatic pulse-by-pulse current limitation

Typical applications : Video Display Units, TV sets, typewriters, microcomputers and industrial applications

Where synchronization is required, use the TEA2019. For more details, see application note AN406/0591

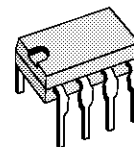

**DIP8**  
(Plastic Package)

**ORDER CODE : TEA2018A**

**PIN CONNECTIONS**

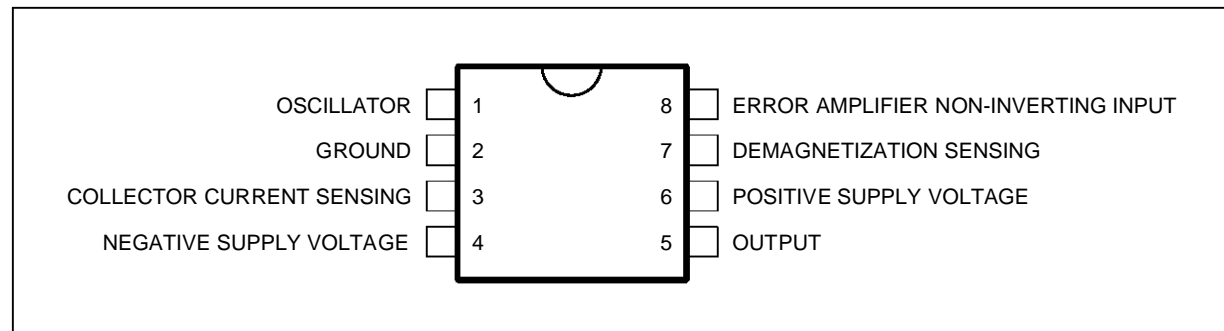

2018A-01.EPS

# TEA2018A

## BLOCK DIAGRAM

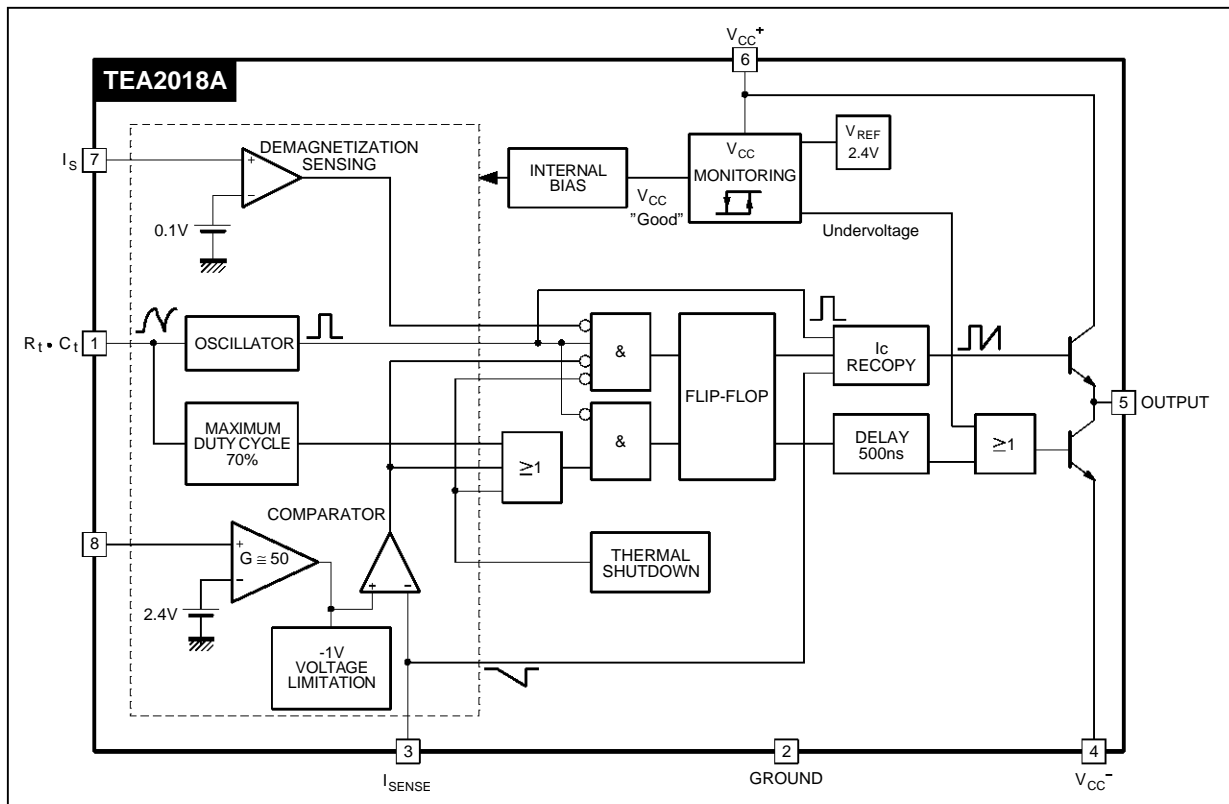

## ABSOLUTE MAXIMUM RATINGS

Symbol	Parameter	Value	Unit
$V_{CC+}$	Positive Supply Voltage	15	V
$V_{CC-}$	Negative Supply Voltage	-5	V
$I_o(\text{peak})$	Peak Output Current (duty cycle < 5%)	$\pm 1$	A
$I_i$	Input Current (Pin 3)	$\pm 5$	mA
$T_j$	Junction Temperature	+150	$^{\circ}\text{C}$
$T_{\text{oper}}$	Operating Ambient Temperature Range	-20, +70	$^{\circ}\text{C}$
$T_{\text{stg}}$	Storage Temperature Range	-40, +150	$^{\circ}\text{C}$

## THERMAL DATA

Symbol	Parameter	Value	Unit
$R_{th(j-a)}$	Junction-ambient Thermal Resistance	80	$^{\circ}\text{C}/\text{W}$

## ELECTRICAL OPERATING CHARACTERISTICS

$T_{\text{amb}} = 25^{\circ}\text{C}$ , potentials referenced to ground (unless otherwise specified) (see test circuit)

Symbol	Parameter	Min.	Typ.	Max.	Unit
$V_{CC+}$	Positive Supply Voltage	6.6	8	15	V
$V_{CC-}$	Negative Supply Voltage	-1	-3	-5	V
$V_{CC(\text{start})}$	Minimum Positive Supply Voltage required for starting ( $V_{CC+}$ rising)		6	6.6	V
$V_{CC(\text{stop})}$	Minimum Positive Voltage below which device stops operating ( $V_{CC+}$ falling)	4.2	4.9	5.6	V

**ELECTRICAL OPERATING CHARACTERISTICS**

$T_{amb} = 25^{\circ}\text{C}$ , potentials referenced to ground (unless otherwise specified) (see test circuit)

Symbol	Parameter	Min.	Typ.	Max.	Unit
$\Delta V_{CC+}$	Hysteresis on $V_{CC+}$ Threshold	0.7	1.1	1.6	V
$I_{CC(sb)}$	Stand-by Supply Current before starting ( $V_{CC+} < V_{CC(start)}$ )		1	1.6	mA
$V_{th(IC)}$	Current Limitation Threshold Voltage (Pin 3)	-1100	-1000	-880	mV
$R_{(IC)}$	Collector Current Sensing Input Resistance		1000		$\Omega$
$V_{7(th)}$	Demagnetization Sensing Threshold	75	100	125	mV
$I_S$	Demagnetization Sensing Input Current (Pin 7 = 0V)		1		$\mu\text{A}$
$\tau_{max}$	Maximum Duty Cycle	60	70		%
$A_V$	Error Amplifier Gain		50		
$I_{I+}$	Error Amplifier Input Current (non-inverting input)		2		$\mu\text{A}$
$V_{REF}$	Internal Reference Voltage	2.3	2.4	2.5	V
$\frac{\Delta V_{REF}}{\Delta T}$	Reference Voltage Temperature Drift		$10^{-4}$		$\text{V}/^{\circ}\text{C}$
$t_{OSC}$	Oscillator Free-running Period ( $R = 59\text{k}\Omega$ , $C = 1.2\text{nF}$ )	44	48	52	$\mu\text{s}$
$\frac{\Delta f_{OSC}}{\Delta T}$	Oscillator Frequency Drift with Temperature ( $V_{CC+} = +8\text{V}$ )		0.05		$\%/^{\circ}\text{C}$
$\frac{\Delta f_{OSC}}{\Delta V_{CC}}$	Oscillator Frequency Drift with $V_{CC+}$ ( $+8\text{V} < V_{CC+} < +14\text{V}$ )		0.5		$\%/V$
$t_{on(min)}$	Minimum Conducting Time ( $C_t = 1\text{nF}$ )		2		$\mu\text{s}$

2018A-04.TBL

**RECOMMENDED OPERATING CONDITIONS**

Symbol	Parameter	Min.	Typ.	Max.	Unit
$V_{CC+}$	Positive Supply Voltage		8		V
$V_{CC-}$	Negative Supply Voltage		-3		V
$I_o$	Output Current			0.5	A
$f_{oper}$	Operating Frequency		30		kHz

2018A-05.TBL

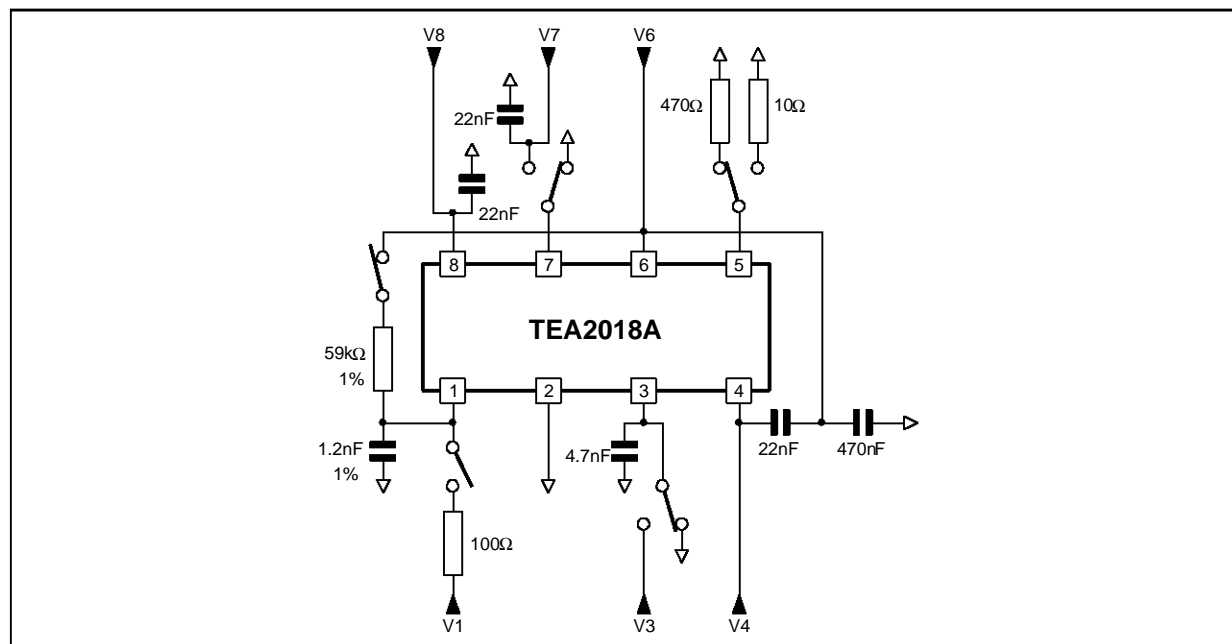
**TEST CIRCUIT**

2018A-03.EPS

**GENERAL DESCRIPTION**

(see application note AN-086)

$$\frac{I_C}{I_B} = \frac{R_B}{R_e}$$

**Operating Principles** (Figure 1)

On every period, the beginning of the conduction time of the transistor is triggered by the fall of the oscillator sawtooth which acts as clock signal. The period  $T_{osc}$  is given by :  $T_{osc} \cong 0.66 C_t (R_t + 200)$  ( $T_{osc}$  in seconds,  $C_t$  in Farad,  $R_t$  in  $\Omega$ )

The end of the conduction time is determined by a signal issued from comparing the following signals :

- a) the sawtooth waveform representing the collector current of the switching transistor, sampled across the emitter shunt resistor,
- b) the output of the error amplifier.

**Base Drive**

- Fast turn-on : On each period, a current pulse ensures fast transistor switch-on. This pulse performs also the  $t_{on(min)}$  function at the beginning of the conduction.
- Proportional base drive : In order to save power, the positive base current after the starting pulse becomes an image of the collector current.

The ratio  $\frac{I_C}{I_B}$  is programmed as follows Figure 2) :

- Efficient and fast switch-off : When the positive base drive is removed, 1ms (typically) will elapse before the application of negative current therefore allowing a safe and rapid collector current fall.

**Safety Functions**

- Overload & short-circuit protection : When the voltage applied to pin 3 exceeds the current limitation threshold voltage  $[V_{th}(I_c)]$ , the output flip-flop is reset and the transistor is turned off. The shunt resistor  $R_e$  must be calculated so as to obtain the current limitation threshold on pin 3 at the maximum allowable collector current.
- Demagnetization sensing : This function disables any new conduction cycle of the transistor as long as the core is not completely demagnetized. When not used, pin 7 must be grounded.
- $t_{on(max)}$  : Outside the regulation area and in the absence of current limitation, the maximum conduction time is set at about 70 % of the period.
- $t_{on(min)}$  : A minimum conducting time is ensured during each period (see Figure 2)
- Supply voltage monitoring : The TEA2018A will stop operating if  $V_{CC}^+$  on pin 6 falls below the threshold level  $V_{CC(stop)}$

**TEST CIRCUIT**

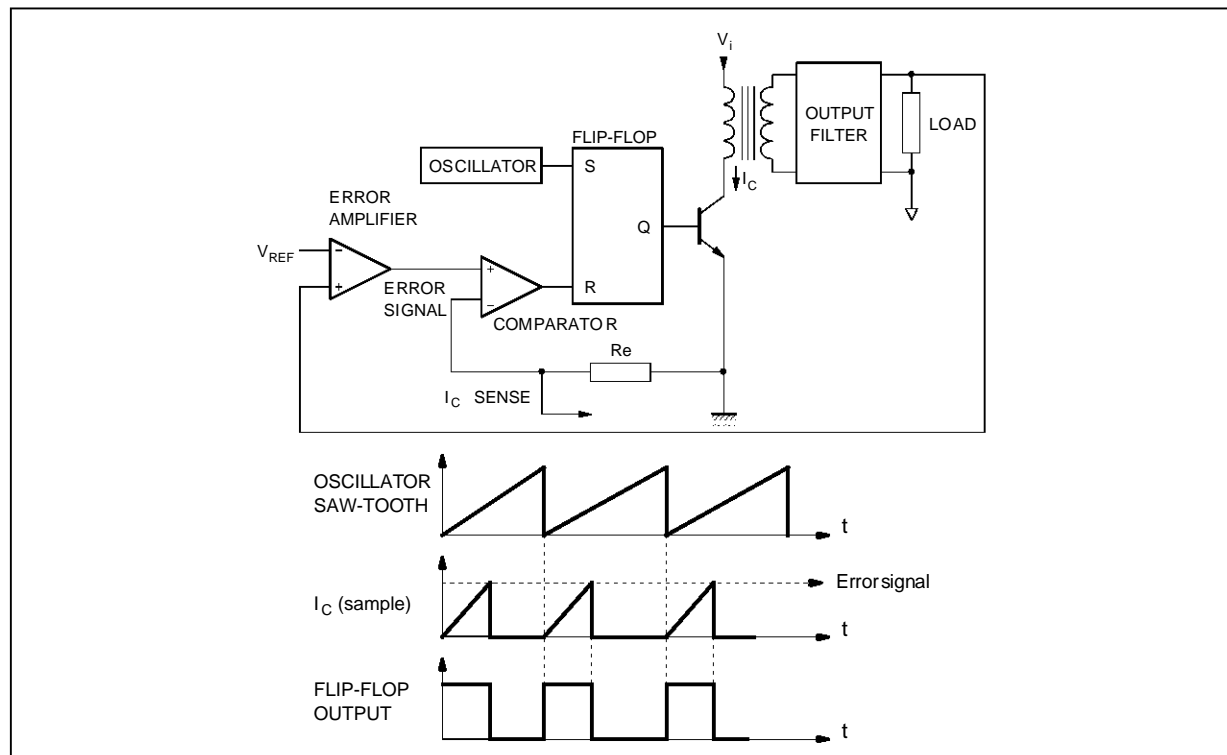

2018A-04.EPS - 2018A-06.EPS





**PACKAGE MECHANICAL DATA**  
8 PINS - PLASTIC DIP

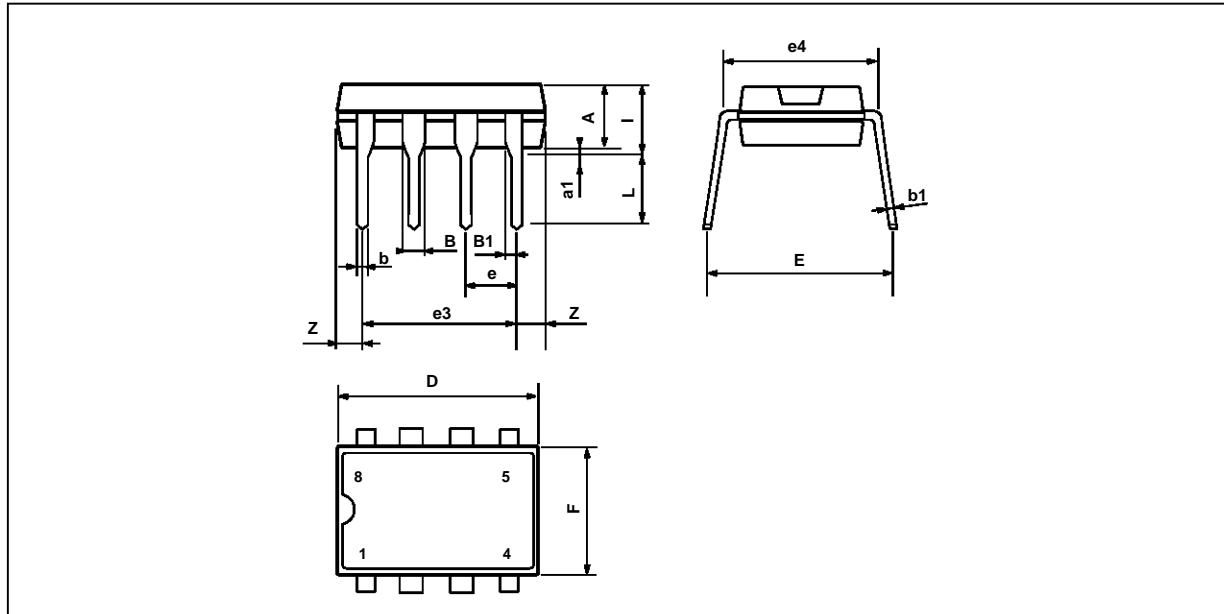

PM-DIP8.EPS

Dimensions	Millimeters			Inches		
	Min.	Typ.	Max.	Min.	Typ.	Max.
A		3.32			0.131	
a1	0.51			0.020		
B	1.15		1.65	0.045		0.065
b	0.356		0.55	0.014		0.022
b1	0.204		0.304	0.008		0.012
D			10.92			0.430
E	7.95		9.75	0.313		0.384
e		2.54			0.100	
e3		7.62			0.300	
e4		7.62			0.300	
F			6.6			0.260
i			5.08			0.200
L	3.18		3.81	0.125		0.150
Z			1.52			0.060

DIP8.TBL

Information furnished is believed to be accurate and reliable. However, SGS-THOMSON Microelectronics assumes no responsibility for the consequences of use of such information nor for any infringement of patents or other rights of third parties which may result from its use. No licence is granted by implication or otherwise under any patent or patent rights of SGS-THOMSON Microelectronics. Specifications mentioned in this publication are subject to change without notice. This publication supersedes and replaces all information previously supplied. SGS-THOMSON Microelectronics products are not authorized for use as critical components in life support devices or systems without express written approval of SGS-THOMSON Microelectronics.

© 1994 SGS-THOMSON Microelectronics - All Rights Reserved

Purchase of I<sup>2</sup>C Components of SGS-THOMSON Microelectronics, conveys a license under the Philips I<sup>2</sup>C Patent. Rights to use these components in a I<sup>2</sup>C system, is granted provided that the system conforms to the I<sup>2</sup>C Standard Specifications as defined by Philips.

SGS-THOMSON Microelectronics GROUP OF COMPANIES

Australia - Brazil - China - France - Germany - Hong Kong - Italy - Japan - Korea - Malaysia - Malta - Morocco  
The Netherlands - Singapore - Spain - Sweden - Switzerland - Taiwan - Thailand - United Kingdom - U.S.A.