

## Double Layer Capacitors

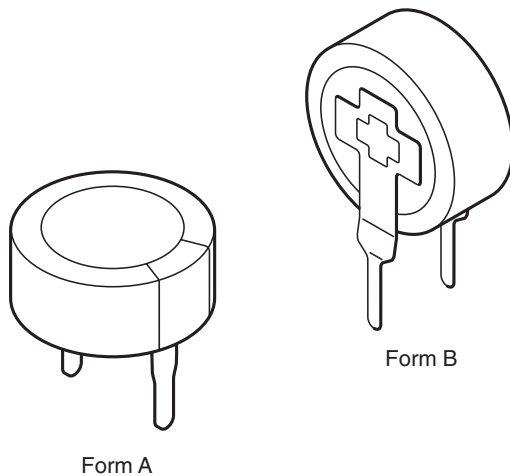

Fig.1 Component outline.

### FEATURES

- Polarized capacitor with high charge density, alternative product to rechargeable backup batteries
- Dielectric: electric double layer
- Radial leads, cylindrical case, insulated with a blue vinyl sleeve
- Available in both vertical and low-profile versions
- Unlimited charge and discharge cycle numbers
- No charge-discharge control circuitry and no series resistor necessary
- Maintenance-free, no periodic replacement or service necessary
- Ecologically beneficial (no Cd, no Li)
- Lead (Pb)-free versions are RoHS compliant.

 Available  
**RoHS\***  
 COMPLIANT

### APPLICATIONS

- Energy storage, for backup of semiconductor memories (CMOS) in all fields of electronics
- Telecommunication, audio-video, EDP
- General industrial, clock and timer systems.

### MARKING

The capacitors are marked with the following information:

- Rated capacitance (in F).
- Rated voltage (in V).
- Date code, in accordance with IEC 60062.
- Name of manufacturer.
- Negative terminal identification.
- Upper category temperature (at 85 °C types only).

QUICK REFERENCE DATA				
DESCRIPTION	VALUE			
	STANDARD FORM A	HIGH VOLTAGE FORM A	HIGH TEMPERATURE FORM A	VERTICAL, MINIATURIZED FORM B
Nominal case sizes (∅D × L in mm)	13 x 7 and 21 x 7.5	13 x 9 and 21 x 9	13 x 9 and 21 x 9	11.5 x 13 (vertical)
Rated capacitance range, C <sub>R</sub>	0.047 to 1.0 F	0.047 to 0.68 F	0.047 to 0.68 F	0.047 to 0.33 F
Tolerance on C <sub>R</sub> at 20 °C	-20 to +80%			
Rated voltage, U <sub>R</sub>	5.5 V	6.3 V	5.5 V	5.5 V
Maximum surge voltage, U <sub>S</sub>	6.3 V	7.0 V	6.3 V	6.3 V
Category temperature range	-25 to +70 °C	-25 to +70 °C	-25 to +85 °C	-25 to +70 °C
Useful life at U <sub>R</sub> :				
at 85 °C	–	–	1000 hours	–
at 70 °C	1000 hours	1000 hours	2800 hours	1000 hours
at 40 °C	8000 hours	8000 hours	23000 hours	8000 hours
at 25 °C	23000 hours	23000 hours	64000 hours	23000 hours
Shelf life at 0 V	1000 hours at upper category temperature			
Climatic category IEC 60068	25/070/21	25/070/21	25/085/21	25/070/21

\* Pb containing terminations are not RoHS compliant, exemptions may apply

<b>SELECTION CHART FOR C<sub>R</sub>, U<sub>R</sub> AND FORM AT UPPER CATEGORY TEMPERATURE (UCT)</b>				
C <sub>R</sub> (F)	FORM	U <sub>R</sub> = 5.5 V		U <sub>R</sub> = 6.3 V
		UCT = 85 °C	UCT = 70 °C	UCT = 70 °C
0.047	A	13 × 9	13 × 7	13 × 9
	B	–	11.5 × 13	–
0.1	A	13 × 9	13 × 7	13 × 9
	B	–	11.5 × 13	–
0.22	A	–	13 × 7	–
	B	–	11.5 × 13	–
0.33	A	–	13 × 7	–
	B	–	11.5 × 13	–
0.47	A	21 × 9	21 × 7.5	21 × 9
	B	–	–	–
0.68	A	21 × 9	–	21 × 9
	B	–	–	–
1.0	A	–	21 × 7.5	–

**DIMENSIONS** in millimeters **AND AVAILABLE FORMS**

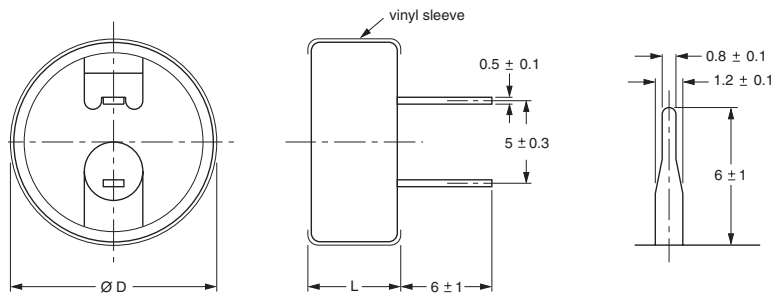

Fig.2 Form A: Low profile.

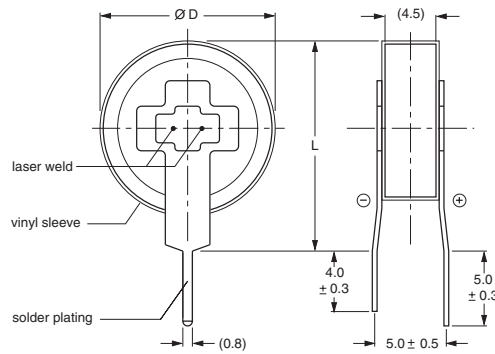

Fig.3 Form B: Vertical.

Table 1

<b>DIMENSIONS</b> in millimeters, <b>MASS AND PACKAGING QUANTITIES</b>						
NOMINAL CASE SIZE ØD × L (mm)	CASE CODE	FORM	ØD <sub>max</sub>	L <sub>max</sub>	MASS (g)	PACKAGING QUANTITIES
11.5 × 13	1	B	11.8	13.5	≈1.5	2000
13 × 7	2	A	13.5	7.5	≈2.8	1000
13 × 9	3	A	13.5	9.5	≈3.4	1000
21 × 7.5	4	A	21.5	8.0	≈7.1	500
21 × 9	5	A	21.5	9.5	≈8.8	500

**Note**

1. Detailed tape dimensions see section 'PACKAGING'.



ELECTRICAL DATA	
SYMBOL	DESCRIPTION
C <sub>R</sub>	rated capacitance, tolerance -20/+80%, measured by constant current discharge method
UCT	upper category temperature
I <sub>L</sub>	max. leakage current after 30 minutes at U <sub>R</sub>
R <sub>i</sub>	max. internal resistance at 1 kHz

**Note**

Unless otherwise specified, all electrical values in Table 2 apply at T<sub>amb</sub> = 20 °C, P = 86 to 106 kPa and RH = 45 to 75%.

**ORDERING EXAMPLE\***

Double layer capacitor 196 series  
1.0 F/5.5 V  
Nominal case size: Ø21 × 7.5 mm; Form A  
Catalog number: 2222 196 12105.

\* To ensure delivery of lead (Pb)-free parts during the transition period, please contact your Vishay sales agent.

Table 2

ELECTRICAL DATA AND ORDERING INFORMATION								
U <sub>R</sub> (V)	C <sub>R</sub> (F)	NOMINAL CASE SIZE ØD × L (mm)	CASE CODE	FORM	UCT (°C)	I <sub>L</sub> 30 min. (µA)	R <sub>i</sub> 1 kHz(Ω)	CATALOG NUMBER
<b>Standard series</b>								
5.5	0.047	13 × 7	2	A	70	69	120	2222 196 12473
	0.1	13 × 7	2	A	70	100	75	2222 196 12104
	0.22	13 × 7	2	A	70	135	75	2222 196 12224
	0.33	13 × 7	2	A	70	182	75	2222 196 12334
	0.47	21 × 7.5	4	A	70	216	30	2222 196 12474
	1.0	21 × 7.5	4	A	70	315	30	2222 196 12105
<b>High temperature series</b>								
5.5	0.047	13 × 9	3	A	85	69	300	2222 196 22473
	0.1	13 × 9	3	A	85	100	200	2222 196 22104
	0.47	21 × 9	5	A	85	216	50	2222 196 22474
	0.68	21 × 9	5	A	85	260	50	2222 196 22684
<b>Vertical, miniaturized series</b>								
5.5	0.047	11.5 × 13	1	B	70	69	120	2222 196 32473
	0.1	11.5 × 13	1	B	70	100	75	2222 196 32104
	0.22	11.5 × 13	1	B	70	135	75	2222 196 32224
	0.33	11.5 × 13	1	B	70	182	75	2222 196 32334
<b>High voltage series</b>								
6.3	0.047	13 × 9	3	A	70	69	300	2222 196 13473
	0.1	13 × 9	3	A	70	100	200	2222 196 13104
	0.47	21 × 9	5	A	70	216	50	2222 196 13474
	0.68	21 × 9	5	A	70	260	50	2222 196 13684

**MEASURING OF CHARACTERISTICS**

**CAPACITANCE (C)**

Capacitance shall be measured by constant current discharge method.

DISCHARGE CURRENT AS A FUNCTION OF RATED CAPACITANCE								
PARAMETER	VALUE							UNIT
Rated capacitance, C <sub>R</sub>	0.047	0.1	0.22	0.33	0.47	0.68	1.0	F
Discharge current, I <sub>D</sub>	0.1			1.0				mA

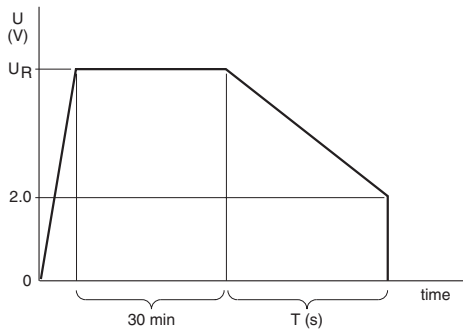

Fig.4 Voltage diagram for capacitance measurement.

Capacitance value C<sub>R</sub> is given by discharge current I<sub>D</sub>, time T and rated voltage U<sub>R</sub>, according to the following equation:

$$C(F) = \frac{I_D(mA) \times 10^{-3} \times T(s)}{U_R(V) - 2}$$

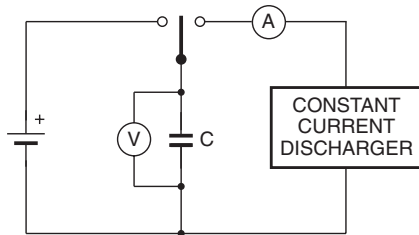

Fig.5 Test circuit for capacitance measurement.

**INTERNAL RESISTANCE (R<sub>I</sub>) AT 1 KHz**

$$R_I(\Omega) = \frac{V_C(V)}{10^{-3}}$$

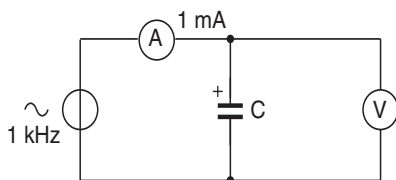

Fig.6 Test circuit for R<sub>I</sub> measurement.

**LEAKAGE CURRENT (I<sub>L</sub>)**

Leakage current shall be measured after 30 minutes application of rated voltage U<sub>R</sub>:

$$I_L(\mu A) = \frac{V(V)}{10^{-4}}$$

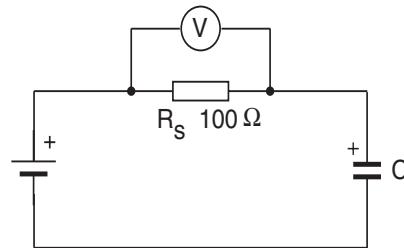
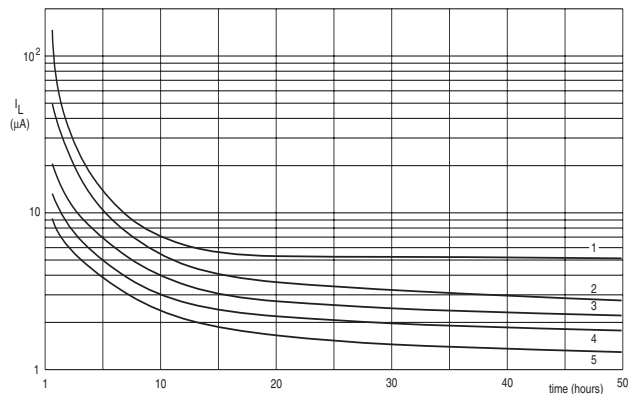

Fig.7 Test circuit for leakage current.



Curve 1: 1.0 F, 5.5 V.  
 Curve 2: 0.47 F, 5.5 V.  
 Curve 3: 0.22 F, 5.5 V.  
 Curve 4: 0.1 F, 5.5 V.  
 Curve 5: 0.047 F, 5.5 V.  
 R<sub>S</sub> = 100 Ω.

Fig.8 Typical leakage current as a function of time.

**DISCHARGE CHARACTERISTICS**

Backup time of 196 DLC series capacitors depends on minimum memory holding voltage and discharge current (corresponding with the current consumption of the load). For minimum backup times of standard and vertical miniaturized series see Figs 9 and 10 (charging time  $\geq 24$  hours).

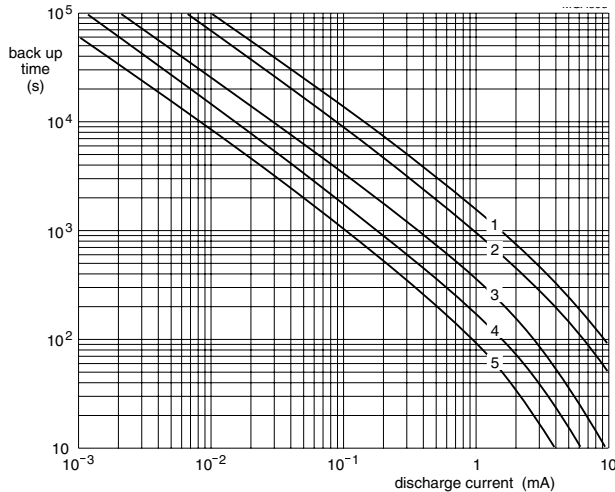

Curve 1: 1.0 F, 5.5 V.  
 Curve 2: 0.47 F, 5.5 V.  
 Curve 3: 0.22 F, 5.5 V.  
 Curve 4: 0.1 F, 5.5 V.  
 Curve 5: 0.047 F, 5.5 V.  
 Voltage drop from 5.0 to 3.5 V.

Fig.9 Typical backup time as a function of discharge current.

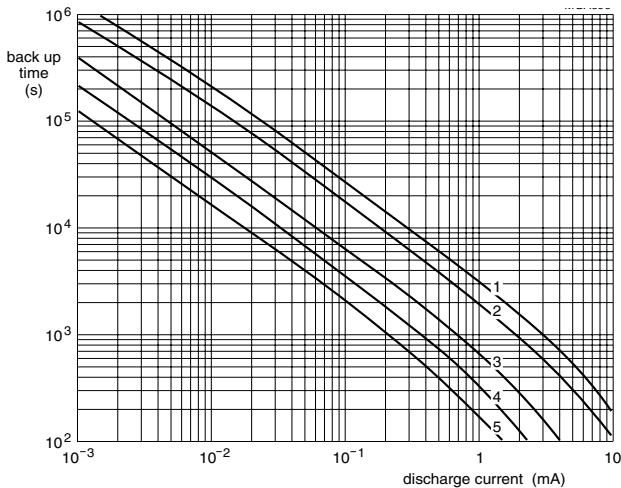

Curve 1: 1.0 F, 5.5 V.  
 Curve 2: 0.47 F, 5.5 V.  
 Curve 3: 0.22 F, 5.5 V.  
 Curve 4: 0.1 F, 5.5 V.  
 Curve 5: 0.047 F, 5.5 V.  
 Voltage drop from 5.0 to 2.0 V.

Fig.10 Typical backup time as a function of discharge current.

Figure 11 shows the backup time when a 196 DLC capacitor is discharged by a constant resistance (charging time  $\geq 24$  hours).

The horizontal axis shows the initial value of discharge current if 5 V is connected to the capacitor via a fixed series resistor.

**EXAMPLE: 1  $\mu$ A CORRESPONDS TO 5 M $\Omega$  AND 0.1  $\mu$ A CORRESPONDS TO 50 M $\Omega$**

The vertical axis shows that period of time during which the voltage drops from 5 to 2 V.

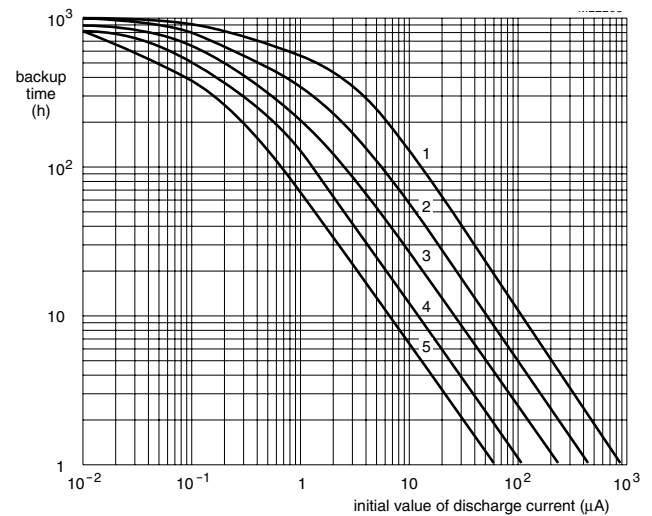

Curve 1: 1.0 F, 5.5 V.  
 Curve 2: 0.47 F, 5.5 V.  
 Curve 3: 0.22 F, 5.5 V.  
 Curve 4: 0.1 F, 5.5 V.  
 Curve 5: 0.047 F, 5.5 V.  
 Voltage drop from 5.0 to 2.0 V by means of a fixed resistor..

Fig.11 Typical backup time as a function of initial discharge current.

Table 3

<b>TEST PROCEDURES AND REQUIREMENTS</b> for standard and vertical miniaturized series (5.5 V; 70 °C)			
NAME OF TEST	IEC 60384-4/ EN130300 subclause	PROCEDURE (quick reference)	REQUIREMENTS
Robustness of terminations	4.4	tensile strength; application of loading force for 10 seconds: 20 N (standard series) 5 N (vertical miniaturized series)	no breaks
Resistance to soldering heat	4.5	solder bath; 260 °C; 5 seconds	$\Delta C/C: \pm 10\%$ $R_I$ and $I_L \leq$ spec. limit
Solderability	4.6	solder bath; 235 °C; 2 seconds	$\geq 75\%$ tinning
Vibration	4.8	10 to 55 Hz; 1.5 mm; 3 directions; 2 hours per direction	$\Delta C/C: \pm 10\%$ $R_I$ and $I_L \leq$ spec. limit
Damp heat, steady state	4.12	500 hours at 55 °C; RH 90 to 95%; no voltage applied	$\Delta C/C: \pm 30\%$ $R_I \leq 4 \times$ spec. limit $I_L \leq 2 \times$ spec. limit
Endurance	4.13	$T_{amb} = 70$ °C; 5.5 V applied; 1000 hours	$\Delta C/C: \pm 30\%$ $R_I \leq 4 \times$ spec. limit $I_L \leq 2 \times$ spec. limit
Storage at upper category temperature	4.17	$T_{amb} = 70$ °C; no voltage applied; 1000 hours	$\Delta C/C: \pm 30\%$ $R_I \leq 4 \times$ spec. limit $I_L \leq 2 \times$ spec. limit
Self discharge	–	24 hours storage at room temperature after application of 5 V for 1 hour	remaining voltage: $\geq 4$ V
Characteristics at high and low temperature	4.19	step 1: reference measurement at +20 °C of C, $R_I$ and $I_L$ step 2: measurement at –25 °C step 3: measurement at +20 °C step 4: measurement at +70 °C step 5: measurement at +20 °C	$\Delta C/C: \pm 30\%$ of +20 °C value $R_I \leq 5 \times$ the +20 °C value $I_L \leq 4 \times$ the +20 °C value



## Notice

Specifications of the products displayed herein are subject to change without notice. Vishay Intertechnology, Inc., or anyone on its behalf, assumes no responsibility or liability for any errors or inaccuracies.

Information contained herein is intended to provide a product description only. No license, express or implied, by estoppel or otherwise, to any intellectual property rights is granted by this document. Except as provided in Vishay's terms and conditions of sale for such products, Vishay assumes no liability whatsoever, and disclaims any express or implied warranty, relating to sale and/or use of Vishay products including liability or warranties relating to fitness for a particular purpose, merchantability, or infringement of any patent, copyright, or other intellectual property right.

The products shown herein are not designed for use in medical, life-saving, or life-sustaining applications. Customers using or selling these products for use in such applications do so at their own risk and agree to fully indemnify Vishay for any damages resulting from such improper use or sale.